



Funded Renewable Solutions for Business

BEHIVE ENERGY
LTD.

T: 01225 920 199 E: biofund@beehiveenergy.co.uk



TOMORROW IS CREATED TODAY

COGETHERM HA-NA150

CHP

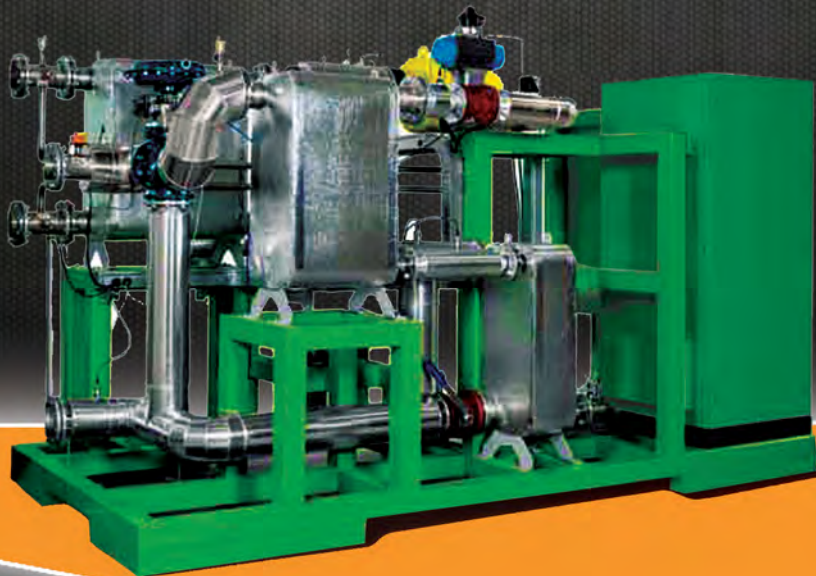

Low-Temperature
Organic Rankine Cycle (LT-ORC)
Power Generation Module



COGETHERM HA-NA150 POWER GENERATION MODULE

Its performances make it ideal for primary power production as well as for waste heat recovery and other low-temperature applications (e.g. geothermal power).

Said thermodynamic cycle in fact, thanks to a special fluid medium, can offer optimal performances in a plant this size, as well as having several advantages over the operational cycles of traditional steam engines and turbines:

- **Low Operational Temperature** allowing the use of “weak” thermal sources.
- **High Condensing Temperature**
- **No Turbine Blade Erosion** which gives higher reliability and lower maintenance costs.
- **Low Operational Pressure** (max 20 bar) meaning higher safety levels, less legal implications, and lower plant costs;
- **No Atmospheric Exhaust** as the Rankine cycle is a closed cycle.
- **No Water or Steam Consumption** leading to lower management costs, less bureaucracy, lower plant complexity.
- **Low Noise Levels** allowing operators to work without hearing protection and leading to less controversies in residential installations.

HA-NA150 modules have been custom designed from scratch

with the purpose of becoming the power generation stage of small power CHP (Combined Heat and Power) plants and heat recovery systems, so to increase efficiency as much as possible we implemented several performance-boosting engineering solutions such as:

- **Low Operational Temperature** allowing the use of “weak” thermal sources.
- **High Condensing Temperature**
- **No Turbine Blade Erosion** which gives
- **Direct Turbine-to-Generator Coupling** which eliminates the performance losses inherent in gearboxes.
- **Custom-Designed Inverters** for each model of module, to obtain optimal output performance.

All of this contributes to give our systems a high thermal efficiency, which in optimal conditions allows them as total system efficiency (thermal power input vs electric power output) up to 15%, a very high value for a system this size.



THE WORKING FLUID

The special working medium we use is the key component which made studying and creating these high-tech solutions possible.

The organic medium used in the system InnoVateq proposes has the following excellent specifications:

- Wide working range (60-165°C) which allows exploiting low-temperature heat sources once thought useless, such as geothermal sources and engine cooling.
- High condensing temperature
- Completely dry in all of its states thus avoiding cavitation and turbine blade erosion.
- Non-toxic, non-flammable, 100% biodegradable and ozone-friendly so even accidental spills are not hazardous.
- Requires little or no reintegration as it works in a closed cycle.
- Requires no filtering/reconditioning thus reducing plant complexity and size.

THE LOW-TEMPERATURE ORGANIC RANKINE CYCLE

The Rankine Cycle concept, invented in the 1800s by the Scottish physicist William Rankine, is quite simple and easily explained with a diagram like the one on the right: a heat source warms up a heat exchanger which transfers the heat to a liquid organic medium, which – exposed to that heat – becomes a gas, greatly increasing its volume. This expanding gas drives a turbine generating mechanical energy (W_{out}) which can be converted into electric power by a generator connected to the turbine shaft. On leaving the turbine, the medium - in gas form - is conveyed to a condenser, where it cools down

returning to its liquid state. Collected in a specific tank it is then pumped back to the heat

exchanger, thus closing the cycle. The low-temperature excess heat the medium releases in the condenser (Q_{out}) can be efficiently used for other uses such as ambiental heating, fuel desiccation/ preheating and so on (combined generation of heat and power).

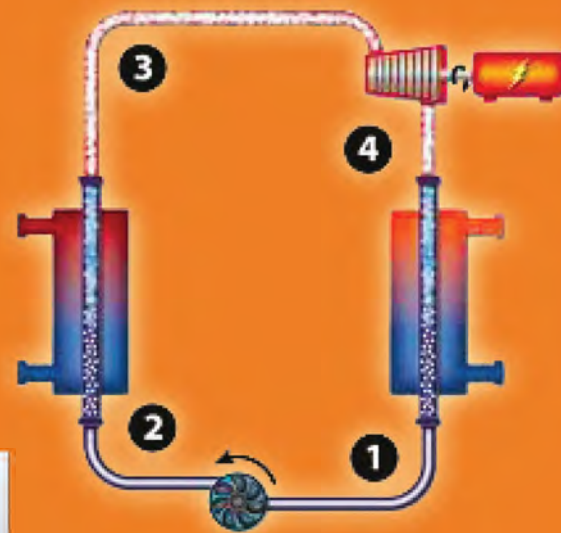
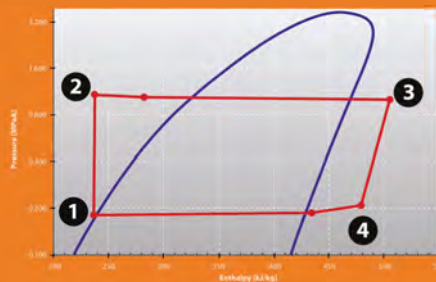

HEAT EXCHANGERS

The heat exchangers mounted on the WES skids are custom-made, welded-plate type units custom designed to optimize performance with our working fluid. The plates, in 316L stainless steel, thanks to their custom design are able to exchange heat efficiently while keeping load losses low, with a significant impact on thermal consumptions. Use of 316L stainless steel, a material widely used in our systems, guarantees extreme cleanliness and long-term reliability.

REMOTE MONITORING

Thanks to remote monitoring via the GPRS cellular network, WES can supervise each ORC Module operation in real time and act promptly on any malfunction thanks to the received diagnostic codes, thus allowing continued optimal operation.

CONTROL PANEL



SPECIFICATIONS TECHNIQUES

THERMAL SUPPLY	
Vector fluid	Overheated water
Hot water input temperature	≥ 155°C
Hot water output temperature	135°C
Thermal Power Input	1100kWt
GENERATOR	
Type	Water-cooled, PM-excited synchronous generator w/rectifier and grid converter
Cooling	Water jacket
Power Output	170kWE
Output Voltage	480-580 VAC
Required Cooling	15kWt
Coolant	Water-Glycol
Coolant Input Temperature	<40°C
Required Coolant Flow	30 l/min
Additional Cooling	Working fluid injection (opt.)
Generator Seal	Gas-tight to PN 25 bar
NET EFFICIENCY	15% (typ.)

TURBINE	
Type	Single-stage, radial with fixed nozzles, indirectly coupled to generator shaft
Input Temperature	145°C
Output Temperature	~95°C
Test Pressure	24 bar
Turbine Body	Welded Steel
Impeller	Aluminium alloy
Speed Control	Feedback Loop On Generator Output Frequency
Working fluid	HFC
Lubrication	Automated, PLC-controlled lubrication system
INVERTER	
Type	IGBT, Grid-Synchronized, Air-Cooled
Power Output	150 kWE
Output Voltage	400 V (360÷445) @ 50Hz ± (47,5÷51,5)
Environment temperature	<40°C
Braking Chopper	Built-in, 600kJ

DIMENSIONS

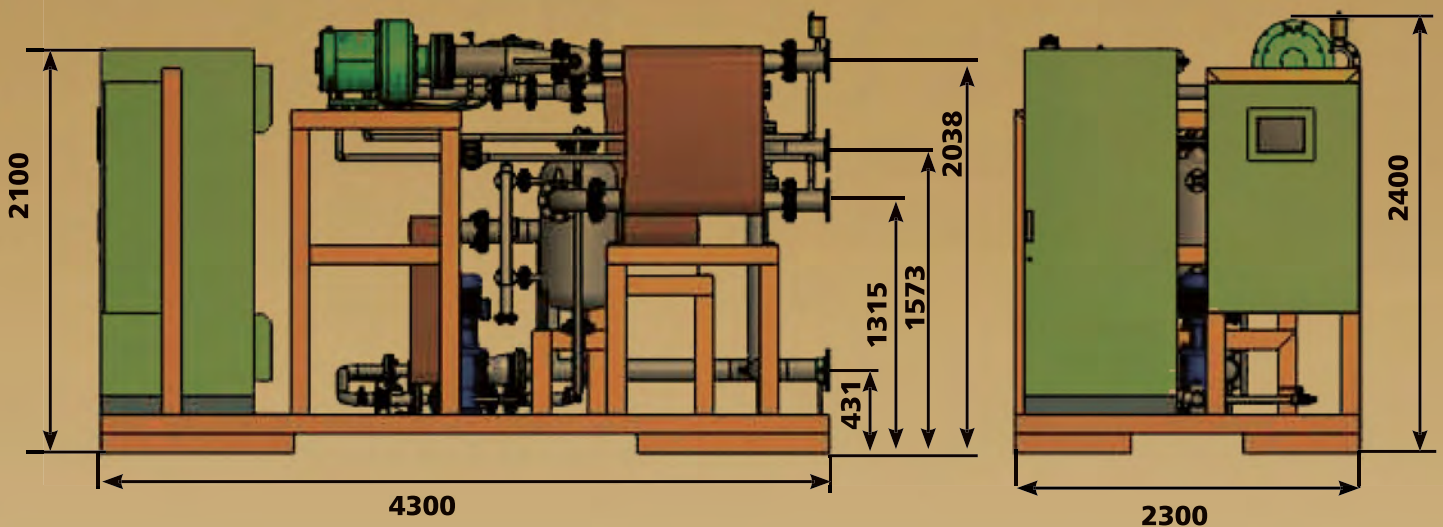

Booths Hall, Chelford, Knutsford, England. WA 16 8GS

Tel: 00 44 161 2617497

www.woodenergysolutions.co.uk

Unit D, Cahir Business Park, Cahir, Co. Tipperary. Ireland

Tel: 00 353 52 7445330

www.woodenergysolutions.com

info@woodenergysolutions.com